

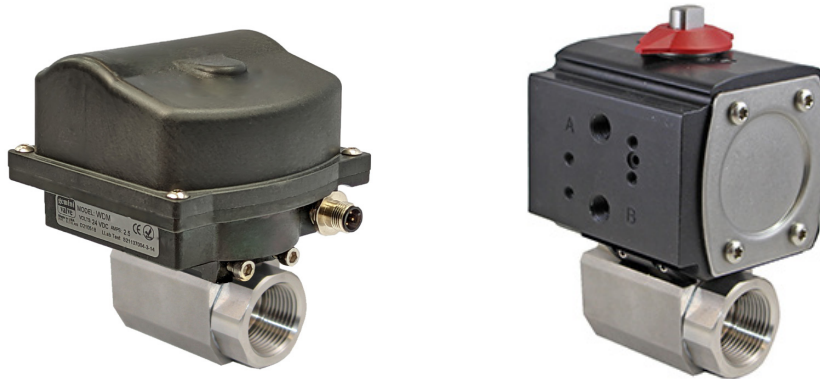

Performance Automation Series Pneumatically and Electrically Actuated Ball Valves



Designed Exclusively for Enduring Automation

Highlights

Ideal for high cycle applications and / or extended service life

Premium quality - low cost - made in USA

Ultra-compact design with fast index time

Unique pneumatic double-acting model with failsafe feature

Can be customized to meet specific application needs

Certified NSF® / ANSI

Performance Engineered Automated Ball Valves

Designed and Tested, Manufactured and Assembled, Supplied
and Supported, Direct from our USA Headquarters



Table of Contents

Performance Automation Series SL01-2602

Product Information

1. Ball Valves
2. Pneumatic Actuators
3. Pneumatic Actuator Accessories
4. Electric Actuators

Product Specifications

5. Ball Valves
6. Pneumatic Actuators
7. Pneumatic Actuator Accessories
8. Electric Actuators

Product Dimensions

9. Pneumatically Actuated Double-Acting
10. Pneumatically Actuated Spring-Return
11. Electrically Actuated

How to Configure Model Number / Sample Request

12. How to Configure Model Number
13. Sample Request

Product Information

Ball Valves

Gemini's Performance Automation Series was designed exclusively for enduring automation. Ideal for a wide variety of OEM and end user applications involving high cycling or extended, maintenance-free service life.

Additionally several materials of construction are NSF® / ANSI 169 certified, making this series suitable for a wide range of commercial cooking equipment and related applications.

Available in standard pipe sizes 1/4" - 1" FNPT. Other sizes or connections may be available upon request.

Typical applications include test, fluid fill, batching, or any application where fast acting positive on / off control is required.

Standard valve body material is CFM8 stainless steel. Other materials may be available upon request. Seals include P.T.F.E. Glass Filled Teflon® seats and Viton® stem and body seals. Viton® alternative elastomer seals are available including E.P.D.M (Ethylene-Propylene-Diene Monomer).

Valve seal leakage can be problematic for high cycle or extended service life applications. Gemini's Performance Automation Series incorporates two unique design features which enable long, leak-tight service life. Please see the following **Stem Detail** and **Mounting Detail** sections to learn more.

Mounting Detail

A key element to ensure long stem seal life is to minimize stem side loading resulting from valve to actuator mis-alignment. Our unique valve to actuator coupling system utilizes a precisely machined locating bonnet and mating actuator gland to ensure nearly perfect alignment.

Two intersecting clamp screws are used to complete the mounting process by pulling the valve into the actuator and locking it rigidly in place. These clamp screws are easy and accessible making the usual chore of joining or separating the valve from the actuator quick and easy.

Additionally, the relative torque between the actuator and valve is absorbed independent of the clamp screw by means of a four corner mounting pad that straddles a mating projection on the valve body. This locks the valve in place and eliminates the risk of the valve loosening while in service.

Are you an OEM with special application requirements? Contact us with the details and if we're a good fit we can design, prototype and manufacture a custom solution to meet your specific requirements.

Stem Detail

While all Gemini Valve ball valves feature a proven wear and thermal compensating stem seal design, Performance Automation series valves further improve stem seal durability with the inclusion of two O-ring seals.

Stem seal integrity is achieved by three independent and distinct elements. A lower, dual purpose stem seal and thrustbearing made from reinforced Teflon® act as a primary static seal. A center O-ring seal provides the main dynamic seal. The gland for this O-ring is located on the stem so that it maintains a predictable preload. Finally, an external O-ring provides both a secondary static and dynamic seal. This final seal is spring compensated to make up for extreme cycling and wear. As the O-ring and Teflon® seals wear, the springs apply a constant axial force on the hardened stainless washer forcing the O-ring below to expand radially and maintain contact with the stem.

The traditional stem (packing) nut has been eliminated and replaced with a captive, fixed-preload retaining ring. This eliminates the danger of incorrectly tightening the nut which can result in premature stem seal wear.

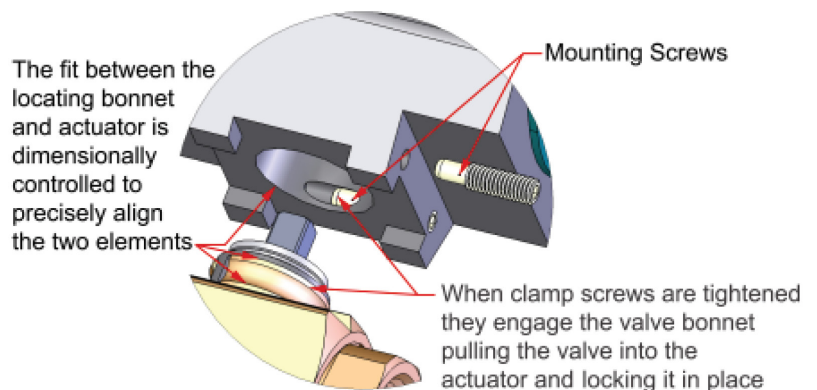

Product Information

Pneumatic Actuators

Gemini's Performance Automation Series Pneumatic Actuators are designed to provide exceptional maintenance-free service life.

Gemini Valve manufactured the first direct mount pneumatically actuated ball valve in 1974. Since then, we have continually gathered feedback from our valued customers to improve upon performance. Our Performance Automation Series Rack & Pinion Pneumatic Actuators combine the industry proven design of our 400 and 500 series legacy models with our latest innovations.

Three pneumatic styles are offered:

Double Acting



Double acting is the most popular pneumatic actuator style in that it offers the most compact size and longest service life at the lowest cost. Cycle or index speed is approximately 1/2 - 1 second.

The C500 model accommodates 1/4" - 1" ball valves and accepts ISO / NAMUE accessories such as Gemini's LS-1 Limit Switch. Basic construction upgrades include a Teflon® impregnated hard anodized coating (PolyLube®), high temperature Viton® internal O-rings and 300 series stainless steel trim.

Actuators can be remotely piloted via means of (2) 1/8" NPT connections or supplied with our model 4GP integral four-way solenoid valve available in a variety of voltages.

Operation: Air supply of 60-125 psi is connected to the solenoid valve. When voltage is supplied to the solenoid valve air cycles into the actuator moving the internal pistons rotating the actuator pinion counter clockwise causing the ball valve to open. When voltage is removed from the solenoid valve air cycles to the opposite side of the pistons rotating the actuator pinion clockwise causing the ball valve to close.

Double Acting with Fail Safe Feature:



Another Gemini Valve industry first. Delivering the service life of a double acting model while retaining the spring return fail safe feature. This unique design minimizes internal wear and mechanical spring fatigue characteristics associated with typical spring return designs. Standard with an integral five-way solenoid valve available in a variety of voltages.

Operation: Upon supply of air to the solenoid valve the internal springs are compressed and will remain compressed as long as there is an air supply to the solenoid valve. The actuator will now operate as a conventional double-acting model and the fail-safe feature will only activate upon loss of air pressure / supply. In the case of a power failure the valve will return to the normal closed position. Cycle or index speed is approximately 1/2 - 1 second. Note; we can also service normally open applications - contact us for details.

Spring Return:



This conventional style spring return model comes with optional model 3GP integral three-way solenoid valve available in a variety of voltages. Cycle or index speed is approximately 1/2 - 1 second. Actuator can also be remotely piloted via means of 1/8" NPT air connection.

Operation: Air Supply of 60-125 psi is connected to the solenoid valve. When voltage is supplied to the solenoid valve air cycles into the actuator moving the internal pistons and compressing the springs rotating the actuator pinion clockwise causing the ball valve to open. When voltage is removed from the solenoid valve the internal springs de-energize moving the internal pistons in the opposite direction rotating the actuator pinion counter-clockwise causing the ball valve to close. Anytime during service should the air supply be disrupted the internal springs will immediately return the ball valve to the closed position.

Product Information

Pneumatic Actuator Accessories

GP Solenoid Valves



Gemini's Performance Automation Series Model GP Solenoid Valves are the ideal pilot valves for our pneumatic actuators. 4GP four-way model for double-acting and 3GP three-way model for spring-return actuators. Utilizing a flush mount NAMUR compatible interface to provide a space efficient design which mounts quickly and easily.

Constructed from corrosion resistant materials including a Teflon® impregnated, hard coat anodized aluminum body, stainless steel spool, and Zytel operator body to ensure long, trouble free life in a variety of environments. A single air connection and DIN style electrical connection are all that is required to complete the automated ball valve package. The Mini-DIN style operating coil is available in a variety of popular voltages and can be adapted to conduit, strain relief, wire lead or automotive style connections.

LS-1 Limit Switch



Limit switches are available for all models (excluding C90) to remotely denote valve position or to interconnect with other devices. The limit switch utilized two mechanical S.P.D.T (Single-Pole, Double-Throw) microswitches which respond to the actuator fully open or fully closed position by means of a cam fitted to the actuator top shaft. U.L.® Listed as Industrial Control Equipment for use in Hazardous Locations, Class I, Groups B, C, & D and Class II, Groups E, F, & G.

Special brackets and shaft extensions available for mounting the Limit Switch, auxiliary equipment including positioners and signal transmitters, requiring NAMUR interface compatibility.

Product Information

Electric Actuators



Gemini's Performance Automation Series Electric Actuators are the ideal alternative for a wide variety of OEM and End User applications where slow, bulky, unreliable, or short life actuation is problematic.

Featuring a quick cycle (index) speed. Enclosed in an ultra-compact enclosure is our durable worm drive transmission powered by a 24VDC gear motor.

The drive train is permanently lubricated for maintenance free operation. Additionally a bearing-supported drive train ensures long, reliable performance.

Featuring a superior mounting system which ensures precise alignment and rigidity. The valve body incorporates a precisely machined locator rail which mates perfectly with the integral actuator coupling.

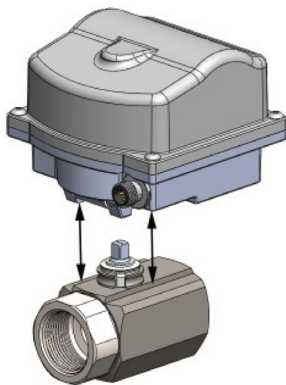

Actuator to valve mounting can be In-Line or Cross Mounted to accommodate installation to confined locations.

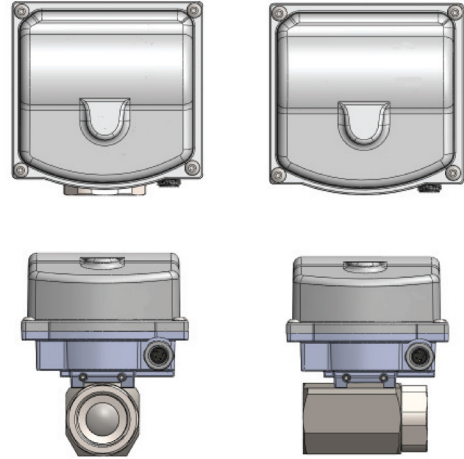

Each actuator is precisely calibrated to ensure accurate and repeatable indexing. The standard model is supplied with 24" 22 gauge wire leads. A variety of electrical terminations are also available upon request.

Position feedback can be sensed by taking advantage of the second pole of the internal stop/start micro switches.

Actuators can be customized to meet specific application requirements. Optional 12VDC motor option available upon request subject to minimum purchase.

Position Control Electric Actuator

Also available in this series is Gemini's "Smart" Electric Actuator which allows for position control via a 4-20mA signal. This option is ideal for throttling applications. V-port ball valves are also available for more precise flow control. See page 9 for technical data or send us an email at SERVICE@GEMINIVALVE.COM

Product Specifications

Ball Valves

TEMPERATURE*:

P.T.F.E. (Glass Filled Reinforced Teflon®) with Viton®: -20° to 400°F
 P.T.F.E. (Glass Filled Reinforced Teflon®) with EPDM: -50° to 250°F

VALVE BODY PRESSURE RATING*: 1,000 P.S.I.** C.W.P.***

MAXIMUM BODY PRESSURE RATING*: 400 P.S.I.**

*See differential pressure - temperature chart below

**P.S.I. = Pounds per square inch

***C.W.P. = Cold working pressure to 150°F

DIFFERENTIAL PRESSURE - TEMPERATURE CHART

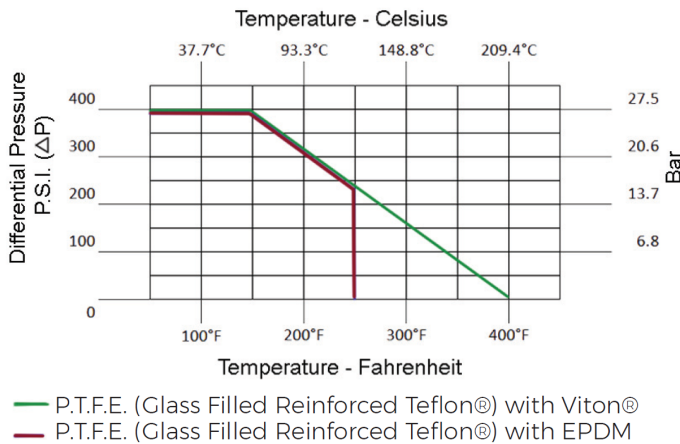

To Use the Pressure - Temperature Chart

Draw an imaginary line from your media Differential Pressure to your media Temperature to confirm it falls within the valve rating based upon the type of seal materials to be used.

To Calculate Pressure Differential

Compare the Upstream media pressure to the Downstream. The pressure differential should not exceed 400 P.S.I. See examples below;

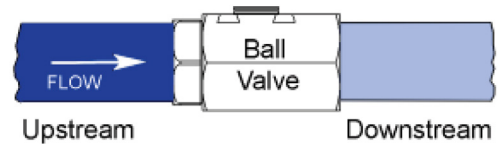

Examples:

Upstream Pressure of 1000 P.S.I. less Downstream of 625 P.S.I. equals 375 P.S.I. which is below 400 P.S.I. differential.

Upstream Pressure of 600 P.S.I. Less Downstream of 0 P.S.I. equals 600 P.S.I. which is above 400 P.S.I. differential - outside of ratings not recommended.

CONNECTION STYLE / SIZE RANGE: 1/4" - 1"

Pipe / N.P.T. Female Screwed End

NOTE: Other connections / sizes may be available upon request.

MATERIALS:

BODY: Brass - ASTM B-16
 Carbon Steel (consult Gemini)
 CF8M Stainless Steel

BALL: Type 316 Stainless Steel

STEM: Type 630 (17-4) Stainless Steel

SEATS AND STEM SEAL:

Glass Reinforced P.T.F.E. (Teflon®) with Viton®
 Glass Reinforced P.T.F.E. (Teflon®) with EPDM

CV:

Note: The values derived from the flow equation are for estimating purposes only. Product variances or systemic factors may alter actual performance. CV values noted apply to 2-way valves only. Consult Gemini for information on CV values for 3-way valve models.

Valve Size	1/4	3/8	1/2	3/4	1
Cv	5.5	5.5	8	12	32

Product Specifications

Pneumatic Actuators

MODELS:



C512D



C512SR5 W/ 5GP



C512SR

TEMPERATURE:
-20°F TO 350°F

AIR CONNECTIONS: Female (2) 1/8" NPT / NAMUR Interface

MATERIALS:

BODY - Aluminum with Teflon® Impregnated Hard Anodized (PolyLube®) Surfaces
EXTERNAL HARDWARE - (Pinion Shaft, Driver, End Caps) 300 Series Stainless Steel
SPRING MODULES - Aluminum with Teflon® Impregnated Hard Anodized (PolyLube®) Surfaces,
300 Stainless Hardware
EXTERNAL TRIM - 300 Series Stainless Steel
O-RINGS - Viton®

ALL MODELS:

CYCLE (INDEX) TIME: Approximately 1/2-1 Second (Load Dependent)

AIR SUPPLY: 60 - 125 psi air. Sufficient air delivery must be available at the actuator to ensure dependable operation. The following precautions should be observed: Air supply should be clean and free of moisture. When dirty or wet air is a problem; a filter / separator should be specified; these units are most effective when installed as close as possible to the actuator. A filter, when used, should permit a minimum flow of 4 scfm at an upstream pressure of 60 psi. Eliminate severe restrictions to air flow (certain solenoid valves & fittings). The most restricted passage must have an area no smaller than .012 inches square, the area of 1/8" diameter orifice. If more than a single actuator is to be supplied by an individual pilot, the minimum passage requirement applies per actuator. All actuator models are permanently lubricated and are not recommended to be used with any other air supply lubricants.

TUBING: For short runs up to 5 feet 5/32" I.D. is suitable, 1/4" I.D. will serve up to 30 feet. For longer runs, use 3/8" I.D. or larger.

Product Specifications

Pneumatic Actuator Accessories

Integral Solenoid Valves

TEMPERATURE: -20°F TO 350°F

AIR SUPPLY / TUBING: see Pneumatic Actuator Specifications

AIR CONNECTION: Female 1/8" NPT for Model 4GP, 1/4" NPT for Model 3GP / 5GP

OPERATING COIL: Operating coil technical data is dependent on the specific model selected, however, all standard coils are designated by the 'SC' code and conform to the following:

Wattage: 5 Watts

Class: F, continuous duty

Protection: IP65 (with connector) dusttight, water resistant, connection: Mini-DIN standard

MATERIALS:

BODY - PTFE / Anodized Aluminum

SPOOL - 18-8 Stainless Steel

SEALS - Nitrile / Viton®

HARDWARE - 18-8 Stainless Steel

COIL / BODY - GF Nylon / GF Zytel



Limit Switch

TEMPERATURE: 10° F TO 180° F

CONDUIT CONNECTION: 1/2" NPT

ELECTRICAL RATING: 10 amp. 250VAC maximum; 1/2 amp. 125VDC; 1/4 amp. 250VDC; 5 amp. 125VAC lamp load. Note: each pole must be the same polarity to utilize these ratings.

MICROSWITCHES: Mechanical S.P.D.T. (Single Pole Double Throw)

INTERNAL WIRING CONNECTORS: Screw Clamp

NEMA STANDARDS: NEMA 1 (General Purpose); NEMA 7 (Hazardous Locations, Class I Groups B, C, & D); NEMA 9 (Hazardous Locations, Class II, Groups E, F, & G); NEMA 12 (Oiltight and Driptight); and NEMA 13 (Oiltight and Dusttight).

UL® LISTINGS: Industrial Control Equipment for use in Hazardous Locations, Class I, Groups B,C, & D and Class II, Groups E, F, & G

MATERIALS:

Body / Cover - Aluminum with Teflon® Impregnated Hard Anodized (PolyLube®) Surfaces

Probes - 316 Stainless Steel

Cover Seal / Probes - Buna N

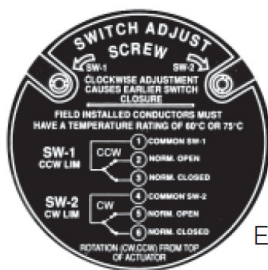

Electrical Schematic
(located in cover)

Switch Adjustment
Screws

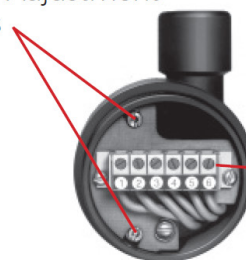

Terminal Strip

Product Specifications

Electric Actuators

TEMPERATURE: 40°F to 221°F

MOTOR: 24VDC

NOTE: Optional 12VDC Available Upon Request. Subject to minimum purchase quantities.

CURRENT (AMPS): Start 2.4, Running 1.2

DUTY CYCLE: 25%

CYCLE (INDEX) TIME: 2 Seconds (approximate - —load dependent)

ELECTRICAL CONNECTION: M12 Connector (optional leads and electrical terminations available upon request)

MATERIALS:

BODY: Coated Aluminum Die Cast Base

ENCLOSURE: Zytel

TRIM (Output Shaft and Mounting Hardware): 300 Series Stainless Steel

WIRING DIAGRAM:

WIRE/CONNECTOR: M12 A-CODED CIRCULAR CONNECTOR

ACTUATION: POLARITY REVERSING

FEEDBACK: STANDARD

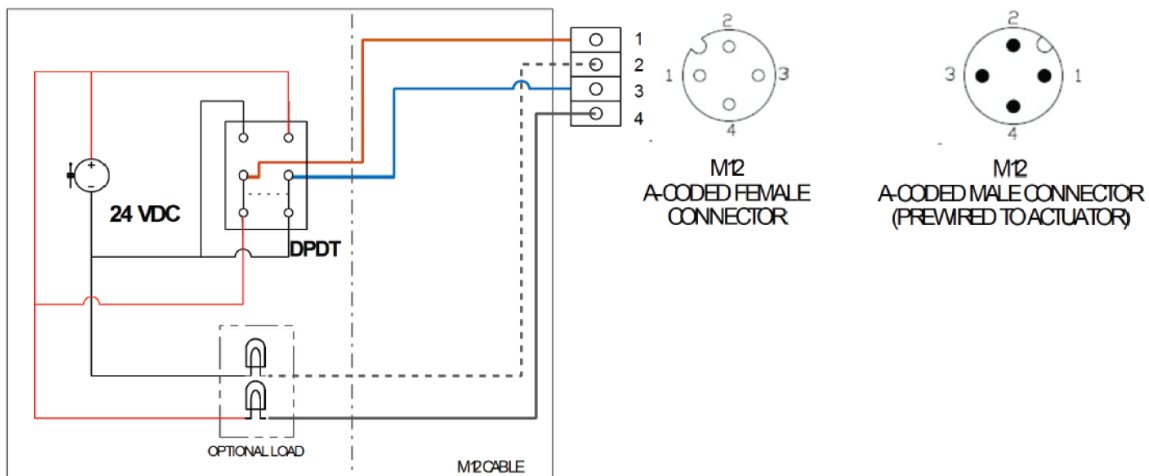

NOTES:
ACTUATOR SHOWN IN CLOSED POSITION.
DASHED LINES REPRESENTS WHITE COLORED LINE.

FIELD WIRING

M12 PIN	STANDARD M12 WIRE COLOR	INPUT/FEEDBACK	CLOSED	CLOSING	OPEN	OPENING
1	BROWN	MOTOR POWER INPUT	+24 VDC	+24 VDC	0 VDC	0 VDC
2	WHITE	FEEDBACK (OPTIONAL)	+24 VDC	OPEN	OPEN	OPEN
3	BLUE	MOTOR POWER INPUT	0 VDC	0 VDC	+24 VDC	+24 VDC
4	BLACK	FEEDBACK (OPTIONAL)	OPEN	OPEN	0 VDC	OPEN

FEEDBACK/OPTIONAL LOAD:

ACTUATOR CLOSED: 24VDC CAN BE MEASURED ACROSS BLUE (M12, PIN 3) AND WHITE (M12, PIN 2).

ACTUATOR OPEN: 24VDC CAN BE MEASURED ACROSS BLUE (M12, PIN 3) AND BLACK (M12, PIN 4).

THE FEEDBACK SIGNAL SHOULD ONLY BE USED FOR MEASUREMENTS OR RUNNING SMALL NON CAPACITIVE LOADS, SUCH AS LEDS, RELAYS SOLENOIDS, IO MODULES, OR SIGNAL LOGIC. IF THE FEEDBACK IS USED TO RUN MORE THAN A SMALL LOAD, THE ACTUATOR MOTOR MAY CONTINUE TO ROTATE PAST THE OPEN AND CLOSED INDEX POSITIONS.

Product Dimensions

Pneumatically Actuated

Model: C512D

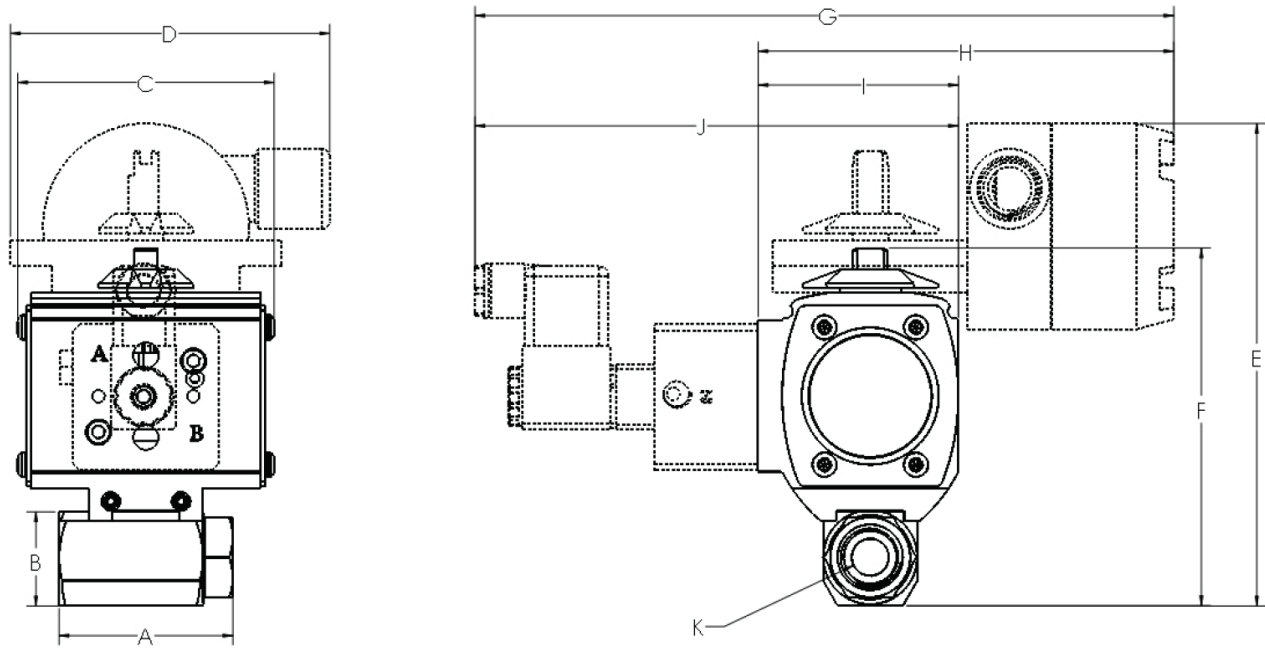

Valve Size	Dimensions (Inches)										
	A	B	C	D	E	F	G	H	I	J	K (Port)
1/4	2.31	1.25	3.41	4.24	6.41	4.75	9.28	5.52	2.66	6.42	.50
3/8	2.31	1.25	3.41	4.24	6.41	4.75	9.28	5.52	2.66	6.42	.50
1/2	2.31	1.25	3.41	4.24	6.41	4.75	9.28	5.52	2.66	6.42	.50
3/4	2.53	1.50	3.41	4.24	6.66	5.00	9.28	5.52	2.66	6.42	.62
1	3.06	1.75	3.41	4.24	6.91	5.25	9.28	5.52	2.66	6.42	.08

Product Dimensions

Pneumatically Actuated

Models: C512SR5 / C512SR

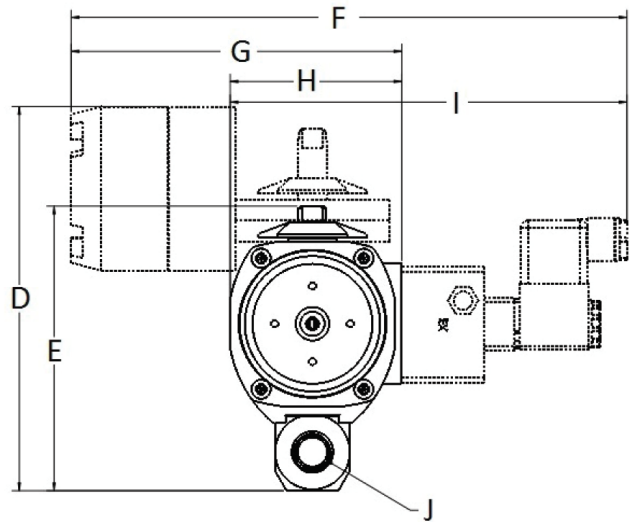
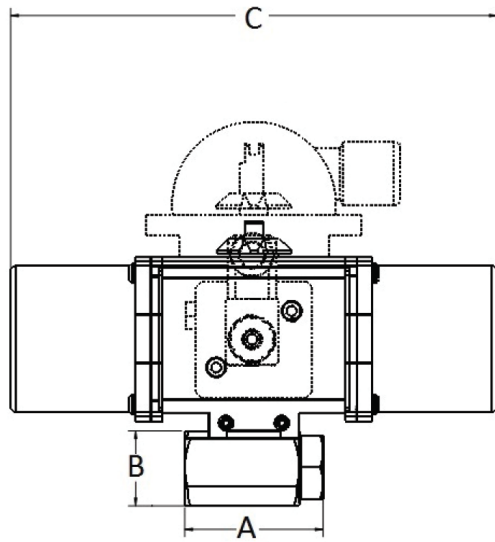

Valve Size	Dimensions (Inches)											
	A	B	C	D	E	F (3GP)	F (5GP)	G	H	I (3GP)	I (5GP)	J (Port)
1/4	2.31	1.25	8.13	6.41	4.75	9.10	9.28	5.52	2.66	6.24	6.42	.49
3/8	2.31	1.25	8.13	6.41	4.75	9.10	9.28	5.52	2.66	6.24	6.42	.49
1/2	2.31	1.25	8.13	6.41	4.75	9.10	9.28	5.52	2.66	6.24	6.42	.49
3/4	2.53	1.50	8.13	6.66	5.00	9.10	9.28	5.52	2.66	6.24	6.42	.62
1	3.06	1.75	8.13	6.91	5.25	9.10	9.28	5.52	2.66	6.24	6.42	.80

Product Dimensions

Electrically Actuated

Model: WDM2402

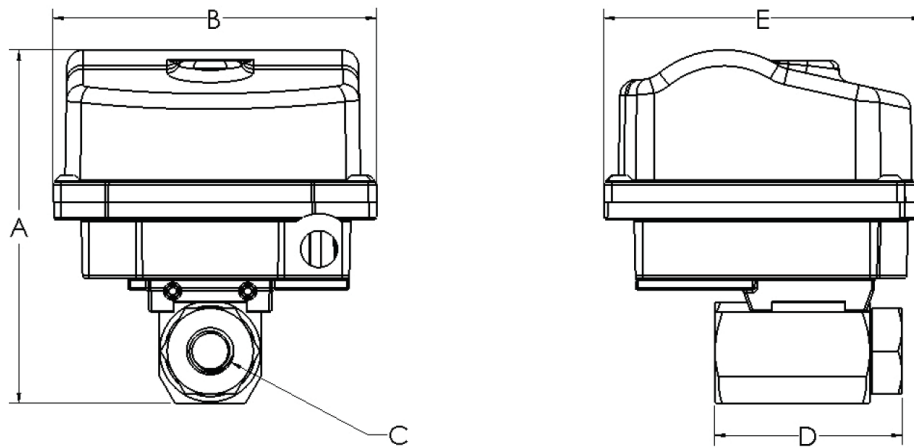

Valve Size	Dimensions (inches)				
	A	B	C	D	E
1/4	4.36	4.00	0.50	2.31	3.94
3/8	4.36	4.00	0.50	2.31	3.94
1/2	4.36	4.00	0.50	2.31	3.94
3/4	4.61	4.00	0.62	2.53	3.94
1	4.86	4.00	0.80	3.06	3.94

How To Configure Model Number

1. Configure Valve

Specify Size and Product Attributes separated with dashes

Example: 1/2 87-1-RTV-6

Size	Product Attributes			
	Model	Body Material	Seal Materials	Ball & Stem Material
1/4	87	1 Brass	RTV P.T.F.E. (Teflon®) & Viton®	6 316 Stainless Steel
3/8		6 CF8M Stainless Steel	RTR P.T.F.E. (Teflon®) & EPDM	
1/2				
3/4				
1				

2. Configure Actuator

Add to Configured Valve (Step 1) to Actuator

Example: 1/2 87-1-RTV-6-C512D

Actuator Model / Type
C512D Pneumatic Double-Acting
C512SR5* Pneumatic Double-Acting with Fail Safe Feature
C512SR Pneumatic Spring-Return
WDM2402 Electric 24VDC

* Must be ordered with 5GP Integral Pilot / Solenoid Valve

3. Configure Optional Actuator Accessory

Add to Configured Valve and Actuator (Steps 1 & 2) to Optional Accessory

Examples: 1/2 87-1-RTV-6-C512D-4GP-SC07D-120VAC-DS

1/2 87-1-RTV-6-C512D-4GP-SC07D-120VAC-DS-LS-1

Actuator Model / Type	Actuator Accessory				
	GP Model NAMUR Integral Pilot / Solenoid Valve				
	Model	Coil Style	Voltage Code	Electrical Connection	Limit Switch
C512D Pneumatic Double-Acting	4GP	SC Standard	07D-VAC 120VAC	DS DIN x Strain	LS-1
C512SR5* Pneumatic Double-Acting with Fail Safe Feature	5GP	MR Manual Override	03D-VDC 24VDC	DC DIN x Conduit; 1/2"	
C512SR Pneumatic Spring-Return	3GP	HL** Hazardous Locations	02D-VDC 12VDC	DA DIN x Field Bus M12	
			06D-VAC 24VAC	DM15 DIN x Molded Lead; 15'	
			08D-VAC 240VAC	C24** Conduit; 1/2" w/ 24" Leads	

* Must be ordered with 5GP Integral Pilot / Solenoid Valve

** HL Coil Style only offered in 120VAC, Conduit Hub 1/2" with 24" Leads

Sample Request

OEMs (Original Equipment Manufacturers)

Gemini Valve provides no cost / obligation samples to OEMs who utilize our product(s) as an integral part of the products they manufacture. To obtain a product sample we simply want to learn the details of your intended application to ensure we are offering the best Gemini Valve solution for your specific application requirements. To obtain samples please call 603 244-7931 or email service@geminivalve.com your application parameters along with the model you are interested in and we will respond promptly.

Plant Engineers, Maintenance Managers and Personnel

Gemini Valve provides samples at little or no cost to Plant Engineers, Maintenance Managers and Personnel who have ongoing or project requirements to enable testing and evaluation of our products. To obtain a product sample we simply want to learn the details of your intended application to ensure we are offering the best Gemini Valve solution for your specific application requirements. To obtain samples please call 603 244-7931 or email service@geminivalve.com your application parameters along with the model you are interested in and we will respond promptly.

All specifications herein are subject to change without notice or obligation. Products are marketed per Gemini Valve Standard Terms & Conditions.

Seller warrants its products for a period of one (1) year, to be manufactured in accordance with our written specifications and free from material defects in material and/or workmanship. Seller, at its option, will promptly repair or replace any products returned intact to the factory, transportation charges prepaid, which Seller determines to be defective in material and/or workmanship. The foregoing shall constitute the sole remedy for any breach of Seller's warranty. Care must be taken to assure that the internal media and external environment are compatible with the materials of the ball valve. For a complete copy of our Warranty please see our Standard Terms and Conditions at www.geminivalve.com

Customer Satisfaction Promise - If for any reason our product(s) or service do not meet / exceed your expectations please contact us for prompt support.